

Applications

- Passive Optical Networks
- FSAN
- Full Duplex Communications
- WDM Bi-Directional transmission over a single fiber
- CATV
- Digital or Analog Operation

Features

- Output Power up to 2 mW CW
- -40 to +85° Operating Temperature
- 1310 or 1550 nm FP MQW Laser Diode
- Low Noise OC-12 PIN TIA Receiver
- Compact, rugged construction
- Low Threshold Current Lasers
- Low Power Consumption
- Available with optical connectors
- Replaces Discreet Lasers and Optical Couplers
- Class 1 Eye Safe Device

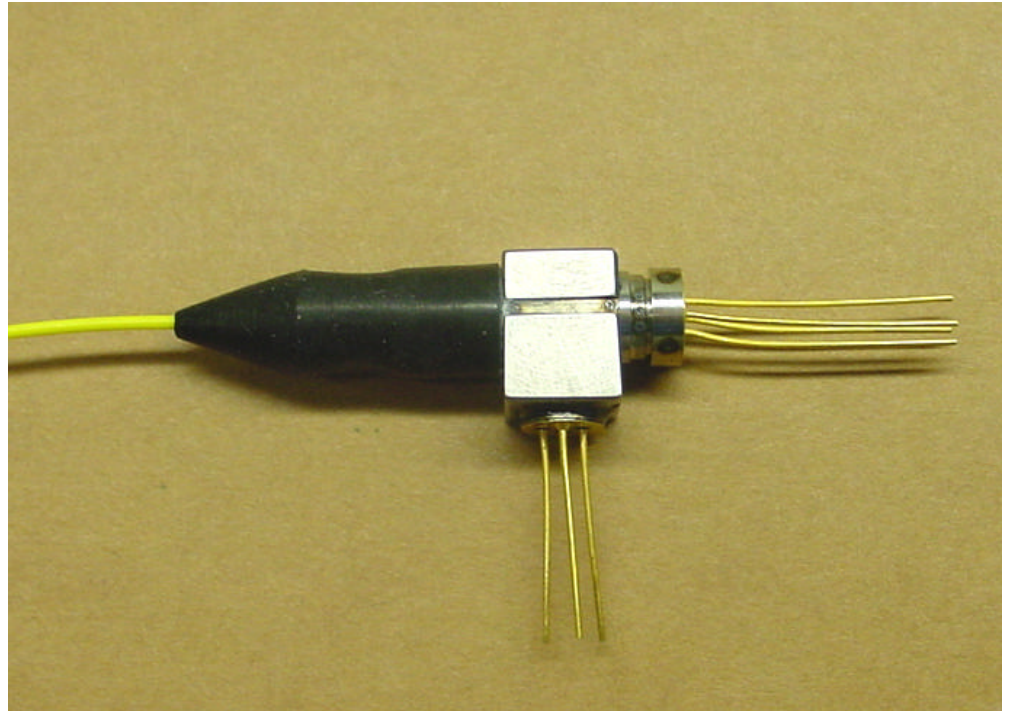

These small, compact modules require minimal board real estate and when used in pairs deliver full duplex operation of a single 9/125um optical fiber with crosstalk of <-47dB.

The PD-LD product incorporates low threshold current, high differential quantum efficiency MQW(Multiple Quantum Well) FP semiconductor lasers whose typical total operating currents are less than 30mA. The receiver section offers a 450MHz bandwidth PIN TIA component that is ideal for digital operation at 622MB/s. These receivers deliver typically -31dBm optical sensitivity at a BER of 10^{-10} at OC-12/STM4 operation. AGC allows for high optical input power.

PD-LD's BiDirectional WDM modules are built to meet the demanding requirements for ATM-PON ONU and LTU applications. See PD-LD's other FSAN and Bidirectional Module offerings for devices optimized for 155MB/s and 1.25 GB/s.

These units combine the electro optic performance and robust mechanical integrity necessary to meet the demands of passive optical networks outlined in FSAN, ITU-G1983.

The PD-LD BiDirectional modules are assembled using laser welding processes. This technique guarantees a semiconductor to optical fiber interface that remains stable over mechanical and environmental and environmental extremes. The optical semiconductor die are mounted within hermetically sealed TO can subassemblies making them impervious to contaminants and moisture.

WDM BiDirectional modules are built with 1 meter long 9/125/900 um SMF28 fiber optic pigtailed. These fibers may be terminated with most standard fiber optic connectors including FC, SC, ST and LC.

PD-LD Inc. is now offering its next generation of WDM style BiDirectional transmitter and receiver modules operating in the 1310 and 1550nm optical windows. These devices are designed to simultaneously transmit and receive over a single optical fiber at frequencies from 10 to 450MHz. Dual wavelength bi-directional modules replace the need for a single mode fiber coupled laser diode, a fiber coupled InGaAs PIN photodiode, a discreet fiber optic WDM and a second stage optical isolator. The BiDirectional Modules combine all of these optical functions and relieve the user of having to fusion splice several discreet units together and then squeeze them onto their PCB.

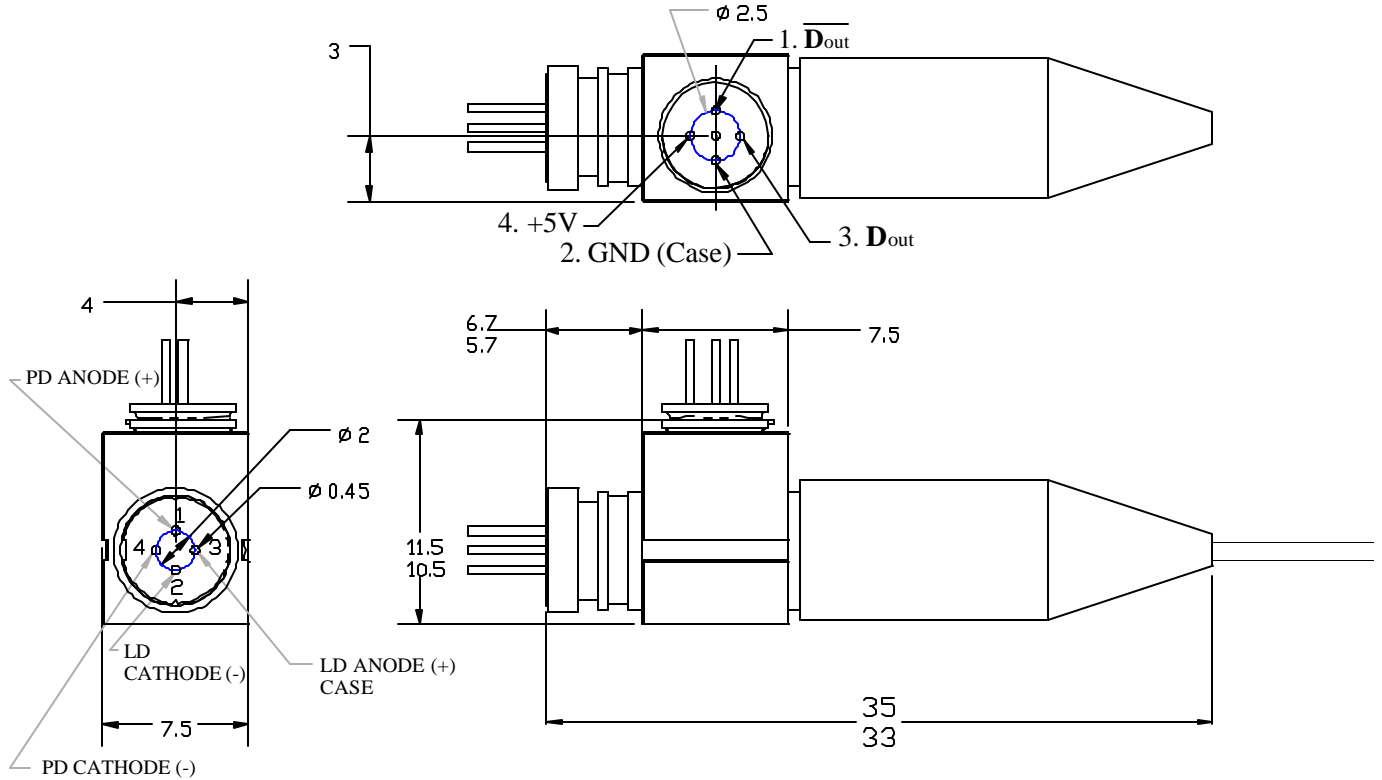

**Absolute
Maximum Ratings
Parameters**

Module	Symbol	Rating	Units
Operating Temp	T_{OP}	-40 to 85	°C
Storage Temp	T_{STG}	-40 to 85	°C
Soldering Temp	T_{SLD}	250	°C
Laser Diode			
Forward Current	$I_{F(LD)}$	100	mA
Reverse Voltage	$V_{R(LD)}$	2	V
Monitor Diode			
Forward Current	$I_{F(MD)}$	2	mA
Reverse Voltage	$V_{R(MD)}$	20	V
PIN TIA			
Forward Current	$I_{F(PD)}$	2	mA
Reverse Voltage	$V_{R(PD)}$	6	V
Max Optical Input Power	P	1.0	mW

BiDirectional Module Characteristics and Parameters

	Symbol	MIN.	TYP.	MAX	Units	Test Condition
Laser Diode						
Power Low	P _O	0.5	0.9		mW	CW
Power Medium	P _O	1.0	1.5		mW	CW
Power High	P _O	2.0	2.5		mW	CW
Threshold Current 1310nm	I _{TH}	-	5	15	mA	CW
Threshold Current 1550nm	I _{TH}	-	10	20	mA	CW
Operating Current	I _{OP}	-	20	35	mA	I _F = I _{OP}
Operating Voltage	V _{OP}	-	1.1	1.5	V	I _F = I _{OP}
Peak Wavelength 1310nm	Lambda	1290	1310	1330	nm	25°C
Peak Wavelength 1550nm	Lambda	1520	1550	1580	nm	25°C
Spectral Width	Delta Lambda	-	1	2	nm	RMS
Temp. Coefficient		-	-	<0.5	nm/°C	-40 to 85°C
Rise/Fall Time	t _r , t _f	-	0.3	0.7	nsec	10~90%
Monitor Diode						
Output	I _{MD}	0.1	0.5		mA	I _F = I _{OP} , P _O
Dark Current	I _{D(MD)}	-	0.01	0.1	μA	V _{R(MD)} =10V
Capacitance	C _(MD)	-	10	20	pF	V _{R(MD)} =10V, f=1MHz
Tracking Error		-1		+1	dB	-40 to 85°C
622 MB/s PIN TIA						
Supply Voltage		4.5	5.0	6	V	DC
Spectral Sensitivity	S	-29	-31	-	dBm	BER=10exp -10
Optical Saturation	P _{max}	-3	0	-	dBm	Average
Output Resistance	R _{out}	-	50	65	?	Differential
Differential Output Voltage	V _d	-	1.3	-	V	DC
Gain	G	0.3	-	30	V/mW	Gain @10MB/s
Module						
Bandwidth	f _C			450 MHz		
Optical Crosstalk	X _{TALK}			-47	dB	

Ordering Information

